



TOWN OF PERINTON

1350 TURK HILL ROAD, FAIRPORT, NEW YORK 14450-8796
(585) 223-0770, Fax: (585) 223-3629, www.perinton.org

BUILDING PERMIT REQUIREMENTS FOR DECKS

1. Submit two copies of a tape location or instrument survey map of the property indicating the proposed location, distance to property lot lines and any overhead wires.
2. Submit two copies of a detailed construction drawing showing a **cross section** (see page 2) and the **top view** (see page 3) with footing depth, connection at house, and deck height above grade. Indicate the size of joists and the distance between beams and house. Indicate size of beams and distance between posts. Provide a detail of proposed guardrails, handrails and stairs. Include an overview showing overall measurements, beams and posts. Approved flashing is required at all points of attachment to the house.
3. Please add the property address to all paperwork submitted.
4. Provide an estimated cost of construction.
5. If construction is being done by a contractor, they must have **General Liability, Workers' Compensation and Disability Benefits** insurance on file with the Town of Perinton before a permit can be issued. Please call the Code Enforcement and Development Department with any questions.
6. Check with the Code Enforcement and Development Department for the required setbacks for the property.
7. Plan review is done by our staff prior to issuing a building permit. After receiving the above information, this review is done in a timely manner. During busy times, the review of a minor project could take up to five business days. We always try to expedite the review, but planning ahead helps us all.
8. At least 24 hours notice is required for inspections. Required inspections are noted on the building permit.
9. Footers must be 42 inches deep and must be inspected before concrete is placed.
10. A Certificate of Compliance (final inspection) is required on all deck permits. **It is the responsibility of the homeowner** to assure that a final inspection has passed and a **Certificate of Compliance has been issued.**
11. Permit Fee: \$.15 per square foot with a \$25 minimum charge.



TOWN OF PERINTON

1350 TURK HILL ROAD. FAIRPORT, NEW YORK 14450-8796
 (585) 223-0770, Fax: (585) 223-3629, www.perinton.org

Example Deck Cross Section

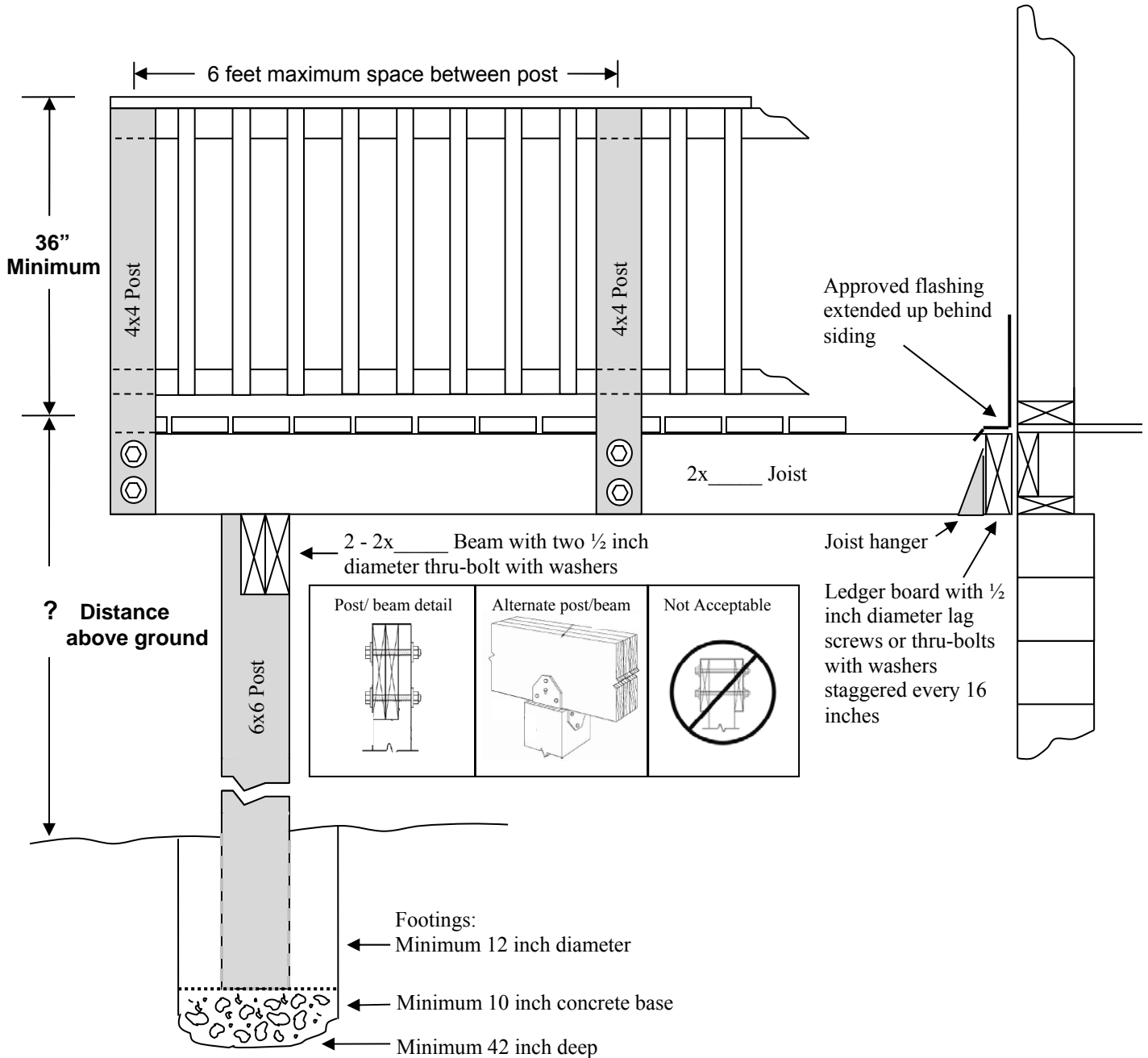



TOWN OF PERINTON

1350 TURK HILL ROAD. FAIRPORT, NEW YORK 14450-8796
 (585) 223-0770, Fax: (585) 223-3629, www.perinton.org

Example Deck Top View

- Add beams as needed to fit your design.
- Fill in dimensions to fit your design.
- Indicate the distance from the ground to the top of the deck.
- **Decks can be free standing and not attached to the house, this would require additional beams.**

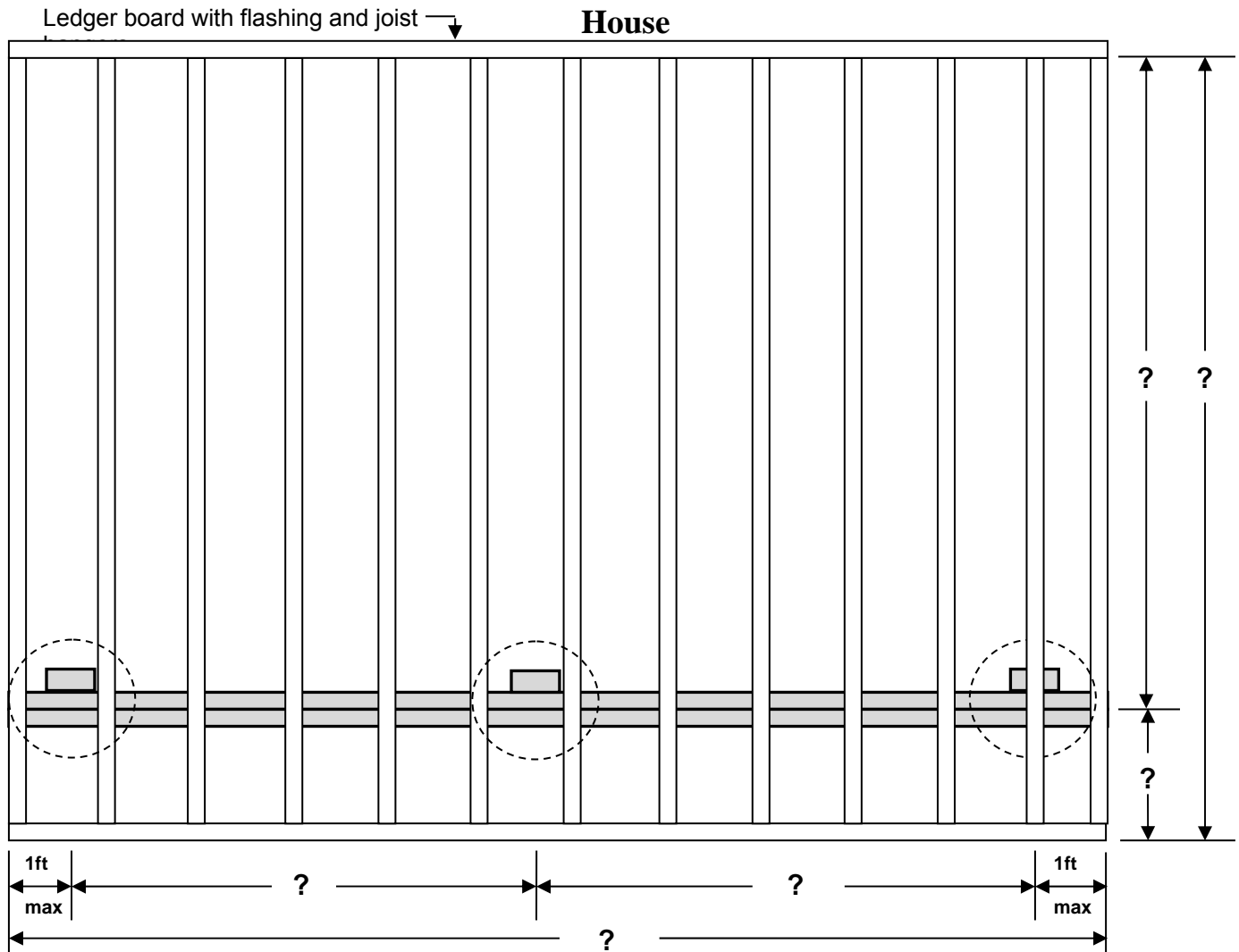



TOWN OF PERINTON

1350 TURK HILL ROAD, FAIRPORT, NEW YORK 14450-8796
(585) 223-0770, Fax: (585) 223-3629, www.perinton.org

Example Pool Deck Top View

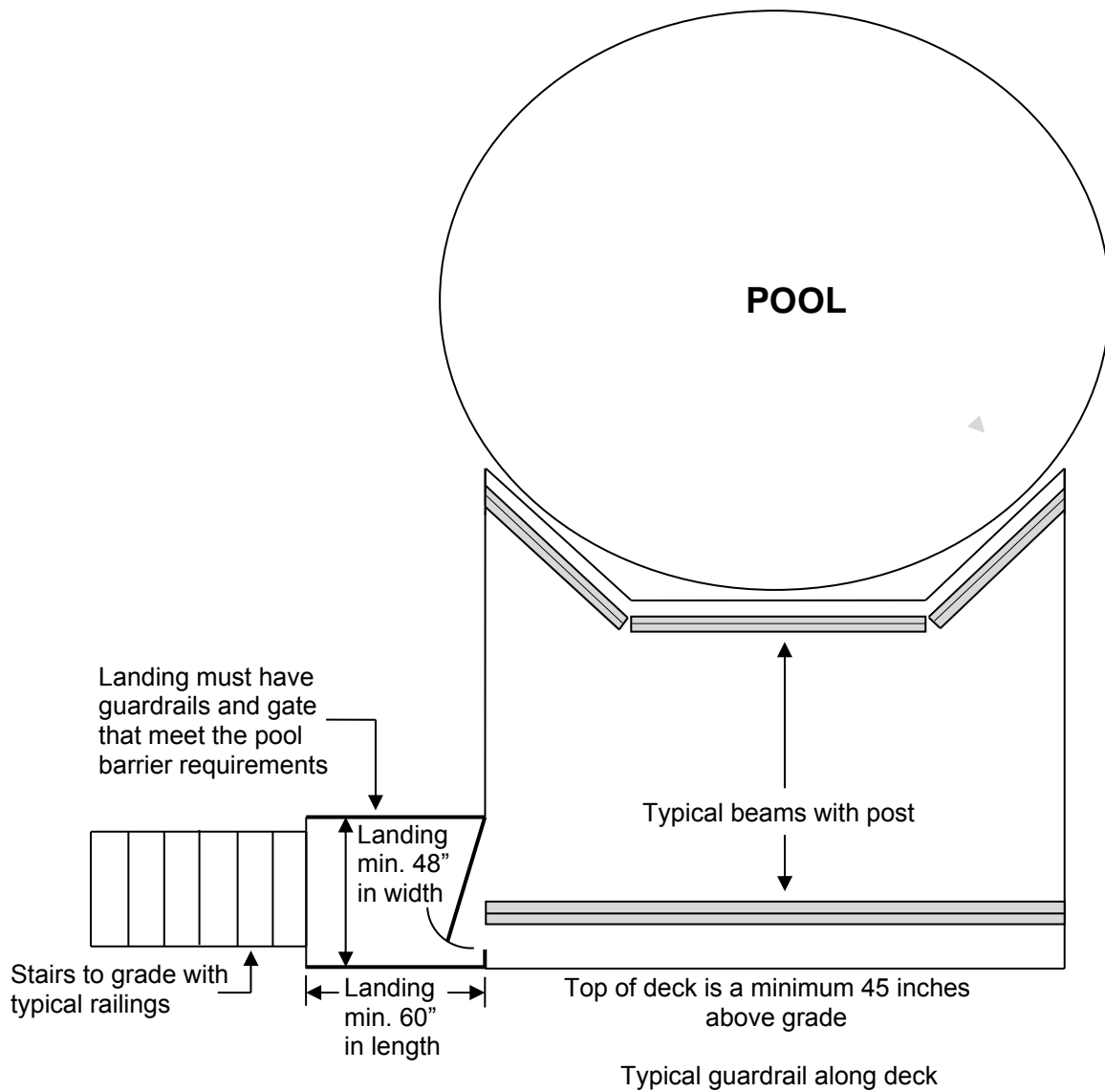



TOWN OF PERINTON

1350 TURK HILL ROAD. FAIRPORT, NEW YORK 14450-8796
 (585) 223-0770, Fax: (585) 223-3629, www.perinton.org

DECK JOIST SPANS FOR COMMON LUMBER SPECIES

SPECIES	SIZE	SPACING OF DECK JOISTS WITH NO CANTILEVER (inches)			SPACING OF DECK JOISTS WITH CANTILEVERS (inches)		
		12	16	24	12	16	24
Southern pine	2 × 6	9-11	9-0	7-7	6-8	6-8	6-8
	2 × 8	13-1	11-10	9-8	10-1	10-1	9-8
	2 × 10	16-2	14-0	11-5	14-6	14-0	11-5
	2 × 12	18-0	16-6	13-6	18-0	16-6	13-6

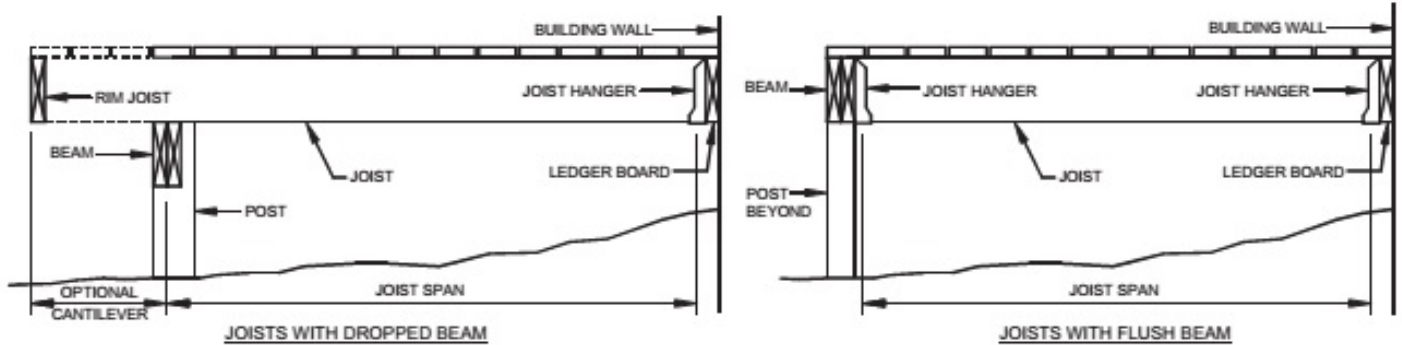

DECK POST TO DECK BEAM CONNECTION

Deck beams shall be attached to deck posts in accordance with the following figure or by other equivalent means capable to resist lateral displacement. Manufactured post-to-beam connectors shall be sized for the post and beam sizes. All bolts shall have washers under the head and nut.

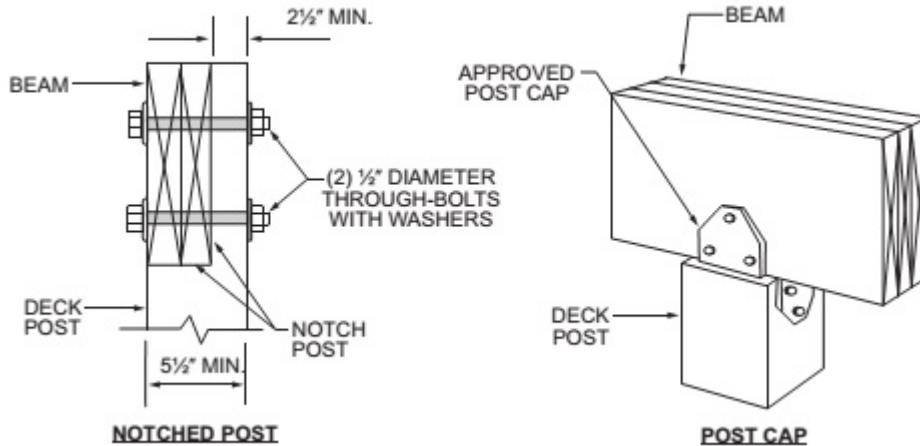



TOWN OF PERINTON

1350 TURK HILL ROAD. FAIRPORT, NEW YORK 14450-8796
 (585) 223-0770, Fax: (585) 223-3629, www.perinton.org

DECK BEAMS

Beam plies shall be fastened with two rows of 10d (3-inch × 0.128-inch) nails minimum at 16 inches on center along each edge. Beams shall be permitted to cantilever at each end up to one-fourth of the actual beam span. Splices of multispan beams shall be located at interior post locations. The ends of each beam shall have not less than 1½ inches of bearing on wood or metal and not less than 3 inches on concrete or masonry for the entire width of the beam.

DECK BEAM SPAN LENGTHS

SPECIES	SIZE	DECK JOIST SPAN LESS THAN OR EQUAL TO: (feet)						
		6	8	10	12	14	16	18
Southern pine	2 – 2 × 6	6-11	5-11	5-4	4-10	4-6	4-3	4-0
	2 – 2 × 8	8-9	7-7	6-9	6-2	5-9	5-4	5-0
	2 – 2 × 10	10-4	9-0	8-0	7-4	6-9	6-4	6-0
	2 – 2 × 12	12-2	10-7	9-5	8-7	8-0	7-6	7-0
	3 – 2 × 6	8-2	7-5	6-8	6-1	5-8	5-3	5-0
	3 – 2 × 8	10-10	9-6	8-6	7-9	7-2	6-8	6-4
	3 – 2 × 10	13-0	11-3	10-0	9-2	8-6	7-11	7-6
	3 – 2 × 12	15-3	13-3	11-10	10-9	10-0	9-4	8-10

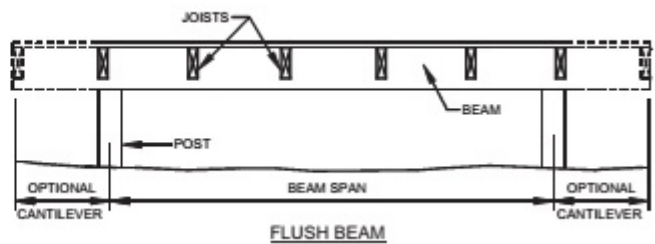
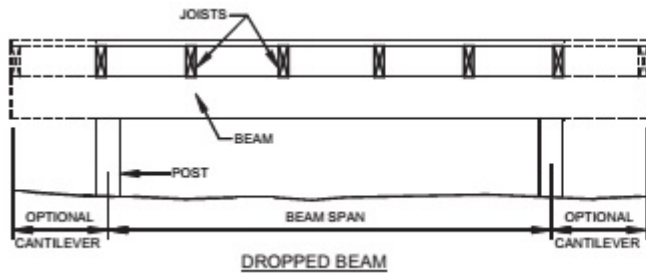

Deck joist and deck beam bearing

The ends of each joist and beam shall have not less than 1½ inches of bearing on wood or metal and not less than 3 inches on concrete or masonry for the entire width of the beam. Joist framing into the side of a ledger board or beam shall be supported by approved joist hangers. Joists bearing on a beam shall be connected to the beam to resist lateral displacement.



TOWN OF PERINTON

1350 TURK HILL ROAD. FAIRPORT, NEW YORK 14450-8796
 (585) 223-0770, Fax: (585) 223-3629, www.perinton.org

LEDGER DETAILS

Deck ledgers shall be a minimum 2-inch by 8-inch nominal, pressure-preservative-treated southern pine, No. 2 grade or better lumber. Fasteners used in deck ledger connections shall be hot-dipped galvanized or stainless steel and shall be installed per the following details.

Deck ledgers shall not support concentrated loads from beams or girders. Deck ledgers shall not be supported on stone or masonry veneer.

DECK LEDGER CONNECTION TO BAND JOIST

CONNECTION DETAILS	JOIST SPAN						
	6' and less	6'1" to 8'	8'1" to 10'	10'1" to 12'	12'1" to 14'	14'1" to 16'	16'1" to 18'
	On-center spacing of fasteners						
1/2-inch diameter lag screw with 1/2-inch maximum sheathing	30	23	18	15	13	11	10
1/2-inch diameter bolt with 1/2-inch maximum sheathing	36	36	34	29	24	21	19
1/2-inch diameter bolt with 1-inch maximum sheathing	36	36	29	24	21	18	16

- Ledgers shall be flashed to prevent water from contacting the house band joist.
- The tip of the lag screw shall fully extend beyond the inside face of the band joist.
- Sheathing shall be wood structural panel or solid sawn lumber.
- Up to 1/2-inch thickness of stacked washers shall be permitted to substitute for up to 1/2 inch of allowable sheathing thickness where combined with wood structural panel or lumber sheathing.

PLACEMENT OF LAG SCREWS AND BOLTS IN DECK LEDGERS AND BAND JOISTS

MINIMUM END AND EDGE DISTANCES AND SPACING BETWEEN ROWS				
	TOP EDGE	BOTTOM EDGE	ENDS	ROW SPACING
Ledger ^a	2 inches ^d	3/4 inch	2 inches ^b	1 5/8 inches ^b
Band Joist ^c	3/4 inch	2 inches	2 inches ^b	1 5/8 inches ^b

- Lag screws or bolts shall be staggered from the top to the bottom along the horizontal run of the deck ledger.
- Maximum 5 inches.
- For engineered rim joists, the manufacturer's recommendations shall govern.
- The minimum distance from bottom row of lag screws or bolts to the top edge of the ledger.

See detail on next page



TOWN OF PERINTON

1350 TURK HILL ROAD. FAIRPORT, NEW YORK 14450-8796
 (585) 223-0770, Fax: (585) 223-3629, www.perinton.org

PLACEMENT OF LAG SCREWS AND BOLTS IN LEDGERS;

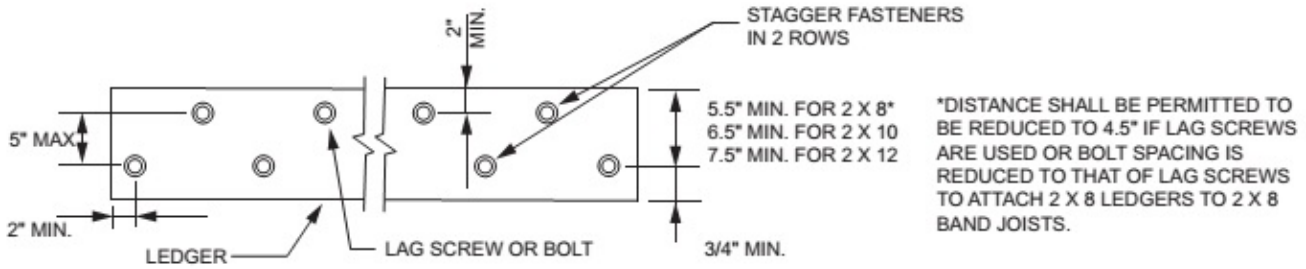

PLACEMENT OF LAG SCREWS AND BOLTS IN BAND JOISTS PARALLEL TO HOUSE FLOOR JOIST;

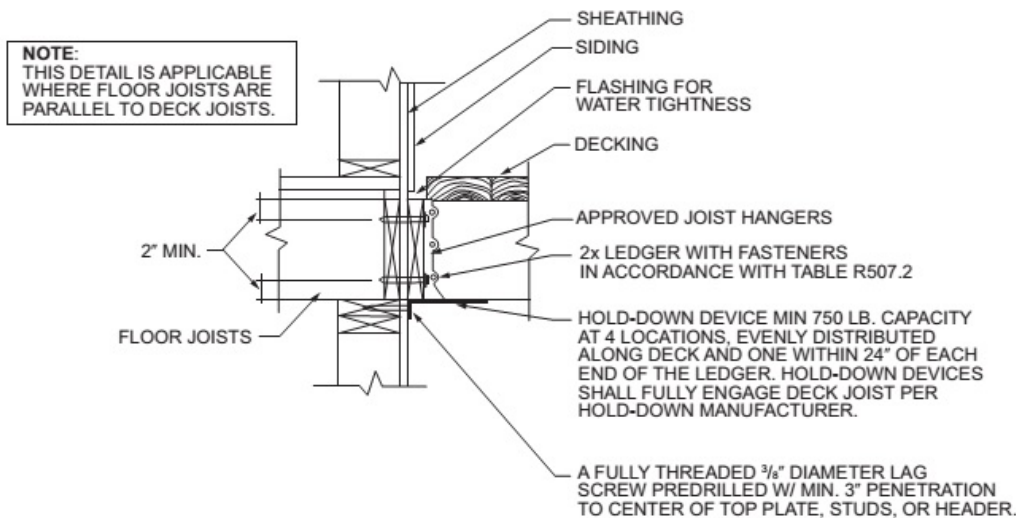

DECK ATTACHMENT FOR LATERAL LOADS;

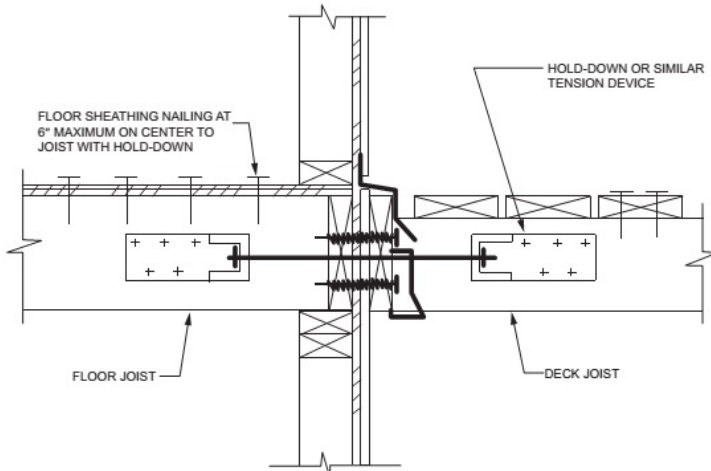



TOWN OF PERINTON

1350 TURK HILL ROAD. FAIRPORT, NEW YORK 14450-8796
(585) 223-0770, Fax: (585) 223-3629, www.perinton.org

Guide Lines for Handrails and Guards

Handrails and guards are two different components.

- A **handrail** is a horizontal or sloping rail intended for grasping by the hand for guidance or support.
- A **guardrail** is a building component located at the open sides of elevated walking surfaces and stairs that minimizes the possibility of a fall from the walking surface to the level below.

Handrails:

1. Handrails shall be continuous on at least one side of each continuous run stairs with 4 or more risers.
2. Top of handrails shall be placed no less than 34 inches or more than 38 inches above the stair nosing.
3. Handrails must be continuous the entire length of the stairs, from a point directly above the top riser to a point directly above the lowest riser, and return to a wall or post.
4. Handrails shall be placed at least 1-1/2 inches from any wall or other obstruction and cannot project more than 4-1/2 inches over the stairs.
5. The handgrip area shall not be less than 1-1/4 inches or more than 2-3/4 inches in width.
 - a. **Type I:** Handrails with a circular cross section shall have an outside diameter of at least 1-1/4 inches and not greater than 2 inches. If the handrail is not circular it shall have a perimeter dimension of at least 4 inches and not greater than 6-1/4 inches with a maximum cross section dimension of 2-1/4 inches.
 - b. **Type II:** Handrails with a perimeter greater than 6-1/4 inches shall provide a graspable finger recess area on both sides of the rail. The finger recess shall begin within a distance of 3/4 inch measured vertically from the tallest portion of the profile and achieve a depth of at least 5/16 inch within 7/8 inch below the widest portion of the profile. This required depth shall continue for at least 3/8 inch to a level that is not less than 1-3/4 inches below the tallest portion of the profile. The minimum width of the handrail above the recess shall be 1-1/4 inches to a maximum of 2-3/4 inches. Edges shall have a minimum radius of 0.01 inch.

Guards:

1. Decks, porches, balconies, ramps or raised floor surfaces located 30 inches or more above the floor or grade below shall have guards not less than 36 inches in height. See pages 2 and 11.
2. Porches and decks which are enclosed with insect screening shall be equipped with guards where the walking surface is located more than 30 inches above the floor or grade below.
3. Open sides of stairs with a total rise of more than 30 inches above the floor or grade below shall have guards not less than 34 inches in height measured vertically from the nosing of the treads.
4. The requirement for guards along open sides of stairs not only applies to the portion of a stairway that is more than 30 inches above the adjacent floor, but it also applies to any portion of a flight of stairs less than 30 inches above the floor.
5. All guards shall have intermediate rails or ornamental closures that prohibit the passage of a sphere 4 inches or more in diameter. The triangular openings formed by the riser, tread and bottom rail of a guard at the open side of a stairway are permitted to be of such a size that a 6-inch sphere cannot pass through. See pages 2 and 11.
6. When designed properly, the top rail of a guard can also serve as the required handrail. See page 10.



TOWN OF PERINTON

1350 TURK HILL ROAD, FAIRPORT, NEW YORK 14450-8796
 (585) 223-0770, Fax: (585) 223-3629, www.perinton.org

HANDRAIL AND GUARD for STAIRS DETAIL, TYPICAL

Handrails must be continuous the full length of stairs
 And cannot be interrupted by any post.

Guards are required for stairs with a total rise of
 30 inches or more.

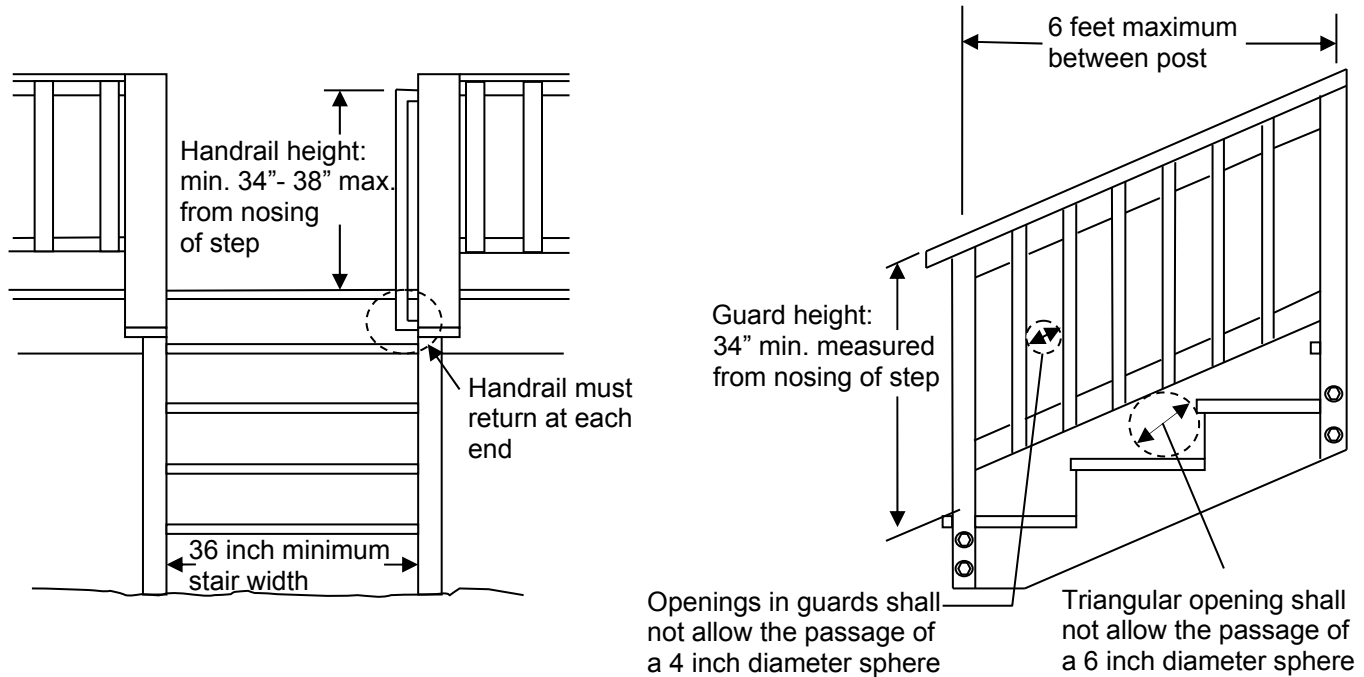

Acceptable Handrail Profiles, typical

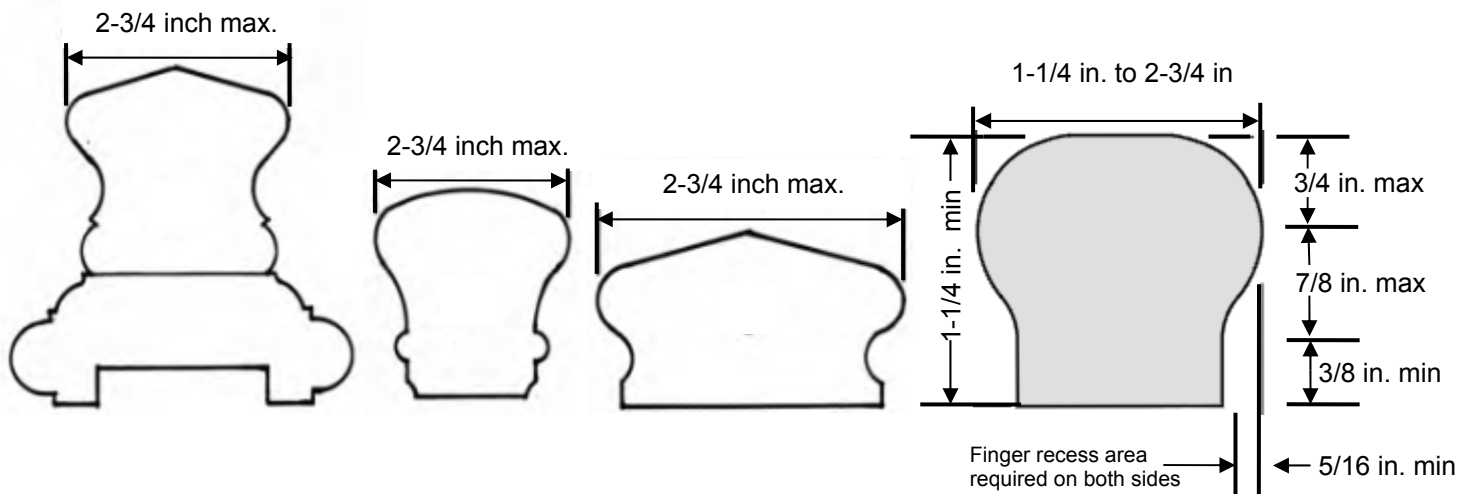



TOWN OF PERINTON

1350 TURK HILL ROAD, FAIRPORT, NEW YORK 14450-8796
 (585) 223-0770, Fax: (585) 223-3629, www.perinton.org

GUARD DETAIL, TYPICAL

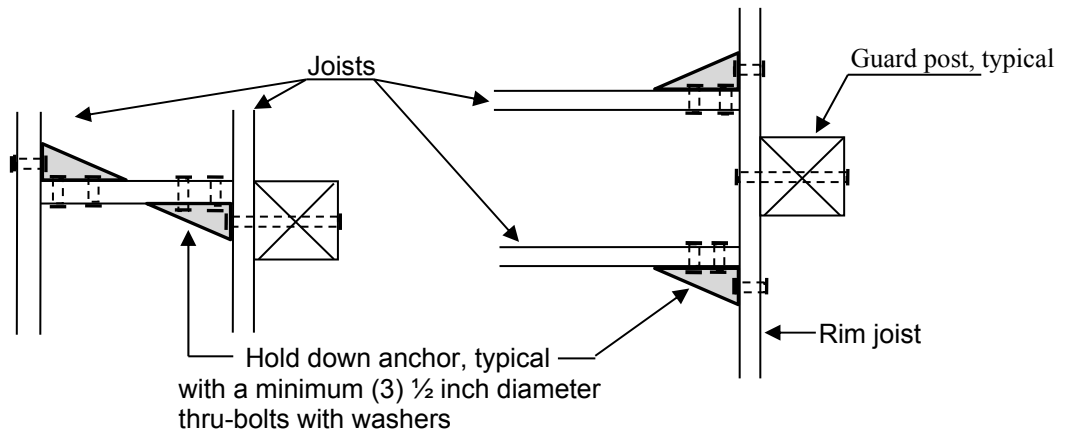
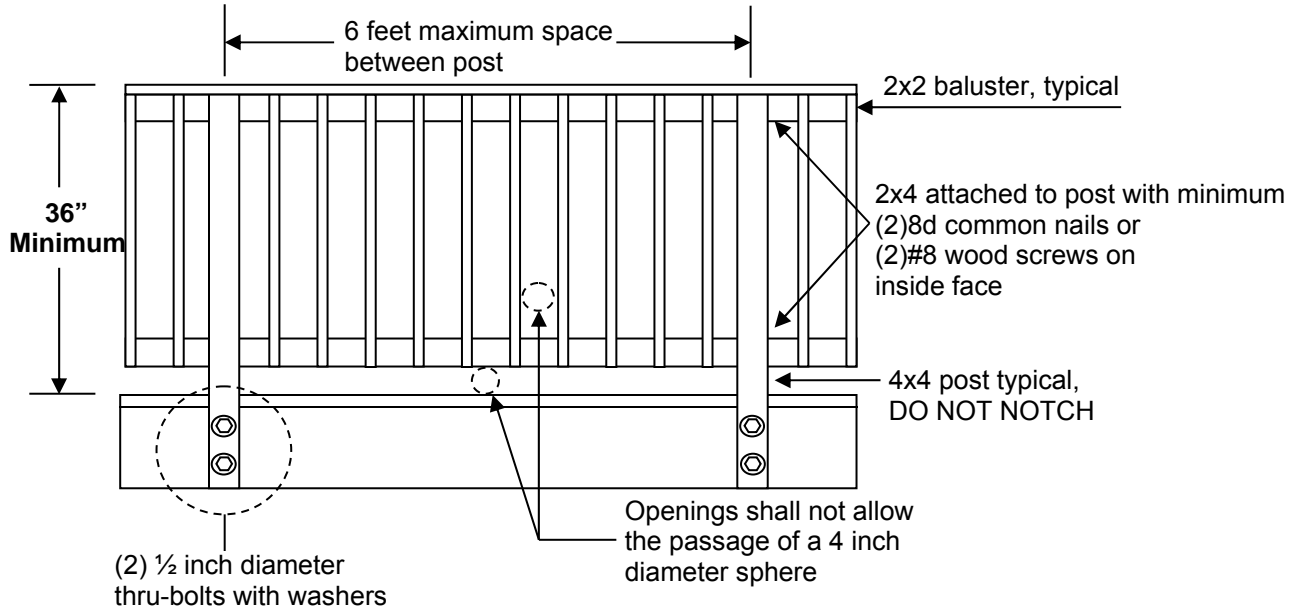

Post can be located on the inside of the joist.



TOWN OF PERINTON

1350 TURK HILL ROAD. FAIRPORT, NEW YORK 14450-8796
 (585) 223-0770, Fax: (585) 223-3629, www.perinton.org

STAIR DETAILS, TYPICAL

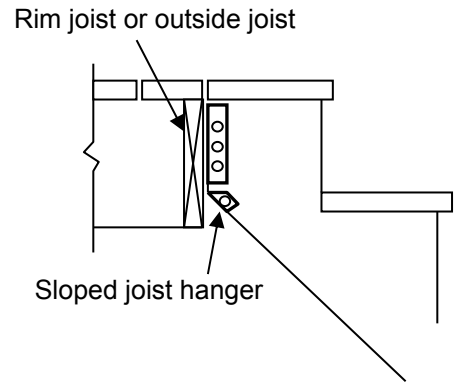
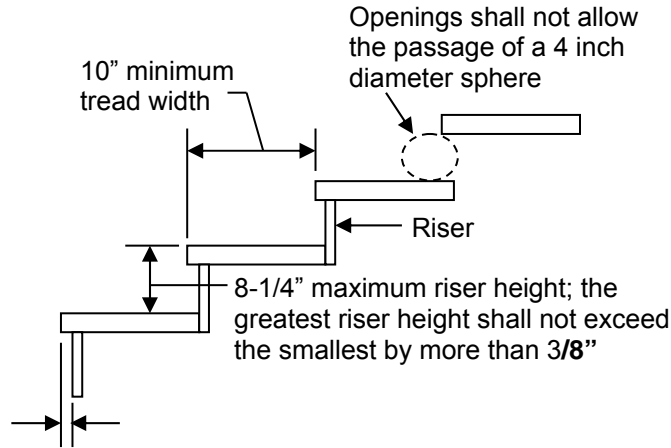

3/4"-1-1/4" nosing; the greatest nosing projection shall not exceed the smallest by more than 3/8"

