

RURAL ROAD SECTION

NTS

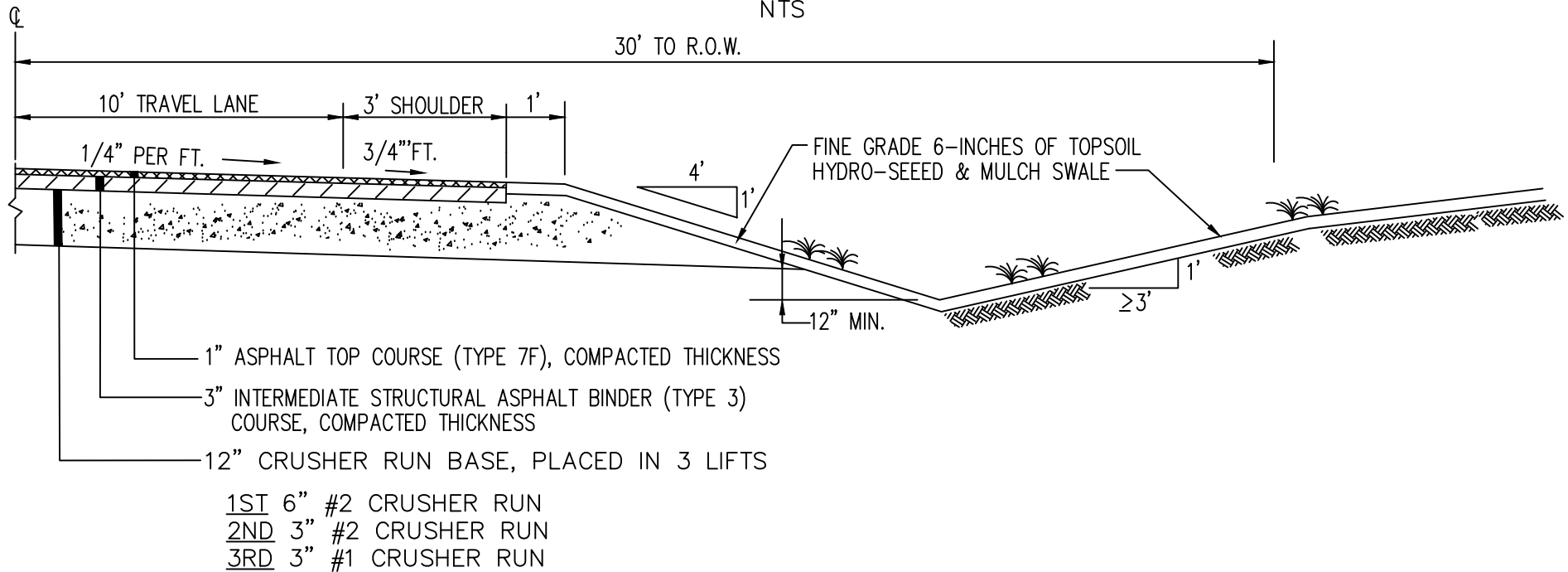

CONDITIONS FOR USE

1. ROADSIDE GRASS SWALES TO HAVE 1% SLOPE MIN.
2. CONCRETE PAVED INVERT TO BE PROVIDED WHEN SWALE SLOPE EXCEEDS 3.5%. IT IS THE DEVELOPERS RESPONSIBILITY TO CONTROL EROSION IN ALL CASES. SOIL AND/OR GRADE CONDITIONS MAY REQUIRE SPECIAL EROSION CONTROL.
3. DRIVEWAY CULVERTS SHALL BE PROVIDED AT EACH DRIVEWAY. PIPE SIZE SHALL CONVEY FLOW IN SWALE, WITHOUT RESTRICTION AND BE A MINIMUM OF 12" IN DIAMETER. SEE DETAIL D-9.
4. THE ROADBOX SUBGRADE AND SUBBASE MATERIAL SHALL BE COMPACTED TO 95% MODIFIED PROCTOR UTILIZING A 10-TON VIBRATORY ROLLER WITH A VIBRATOY FORCE OF 27,000 LBS.
5. THIS SECTION MAY BE USED IN RT & RS ZONING ONLY FOR A ROADWAY SERVING 12 UNITS OR LESS. LOTS SERVED SHALL BE ON (1) ACRE OR GREATER WITH ROAD FRONTAGE IN EXCESS OF 150'. RURAL ROAD CANNOT BE USED OFF EXISTING ROADS WITH AN EDGE TREATMENT.
6. PAVEMENT SUBGRADE DRAINAGE AND STABILITY TO BE ACCEPTABLE TO THE TOWN OF PERINTON.