

# MAILBOX DETAIL

N.T.S.

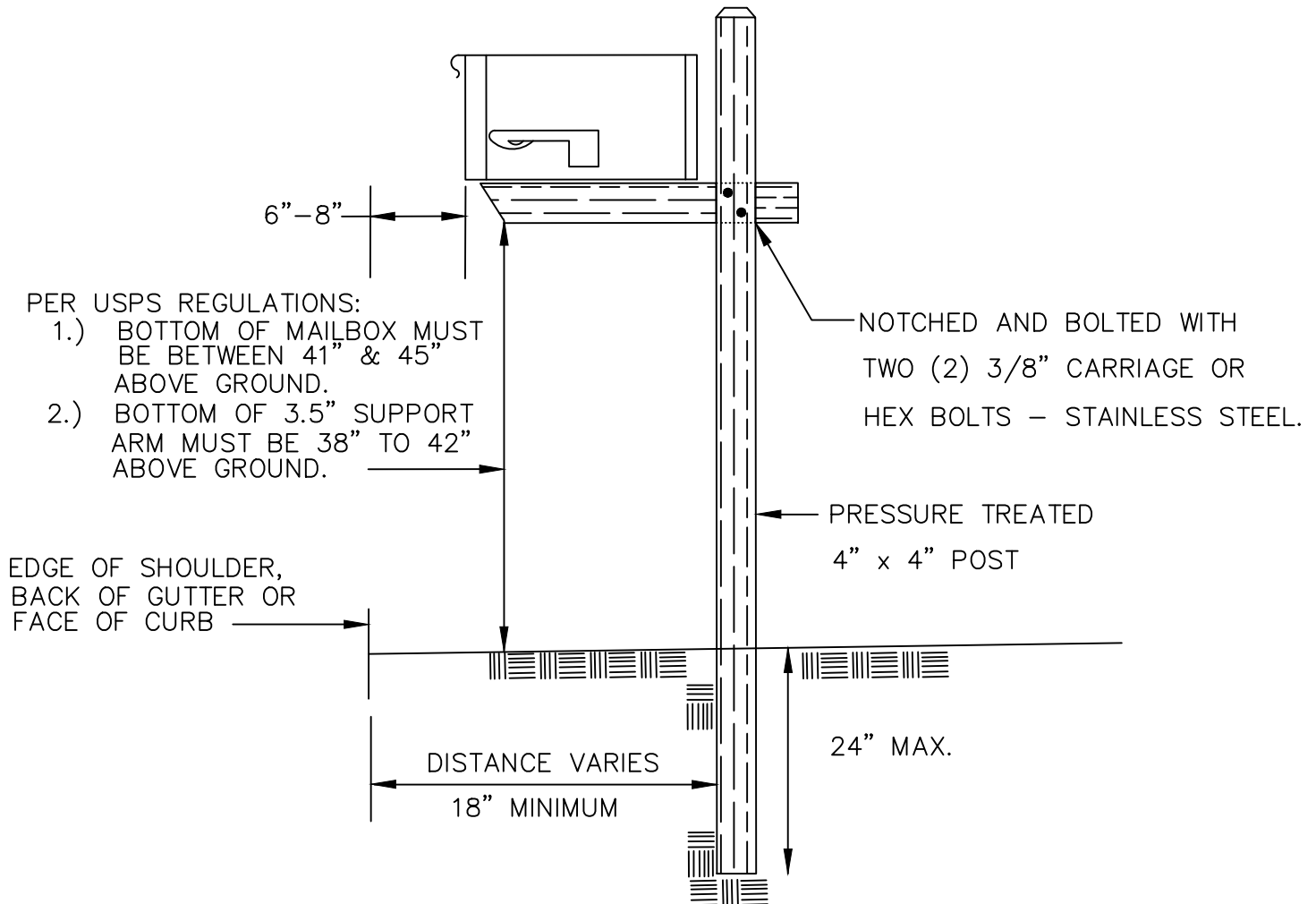

## MAILBOX SUPPORTS

SUPPORTS FOR MAILBOXES SHOULD BE OF ADEQUATE STRENGTH AND SIZE TO SUPPORT THE BOX PROPERLY. HOWEVER, CUSTOMERS SHOULD AVOID THE USE OF MASSIVE MAILBOX SUPPORTS THAT, WHEN STRUCK, COULD DAMAGE VEHICLES AND CAUSE SERIOUS INJURY TO VEHICLE OCCUPANTS. HEAVY METAL POSTS, CONCRETE POSTS, AND MISCELLANEOUS ITEMS OF FARM EQUIPMENT SUCH AS MILKCANS FILLED WITH CONCRETE ARE EXAMPLES OF POTENTIALLY DANGEROUS SUPPORTS. THE IDEAL SUPPORT IS AN ASSEMBLY THAT BENDS OR FALLS AWAY FROM A STRIKING VEHICLE. DOMESTIC MAIL MANUAL (DMM) SECTIONS 156.531, 156.54, 157.32C, AND 157.4 INCLUDE POSTAL REGULATIONS REGARDING THE CONSTRUCTION AND PLACEMENT OF MAILBOXES AND SUPPORTS ON RURAL AND HIGHWAY CONTRACT ROUTES.

THE FEDERAL HIGHWAY ADMINISTRATION (FHWA) HAS DETERMINED THAT MAILBOX SUPPORTS NO LARGER THAN 4 INCHES BY 4 INCHES, A 4 1/2-INCH DIAMETER WOOD POST, OR A 2-INCH DIAMETER STANDARD STEEL OR ALUMINUM PIPE BURIED NO MORE THAN 24 INCHES, SHOULD SAFELY BREAKAWAY IF STRUCK BY A VEHICLE. THE MAILBOX MUST ALSO BE SECURELY ATTACHED TO ITS POST TO PREVENT SEPARATION WHEN STRUCK.

**D42**

JANUARY 2021